

ROBOWRAP

OVERSIZED PALLETS - BIG BOXES - PALLETS

Ask for details



PRE-STRETCH SYSTEM



MECHANICAL BRAKE SYSTEM

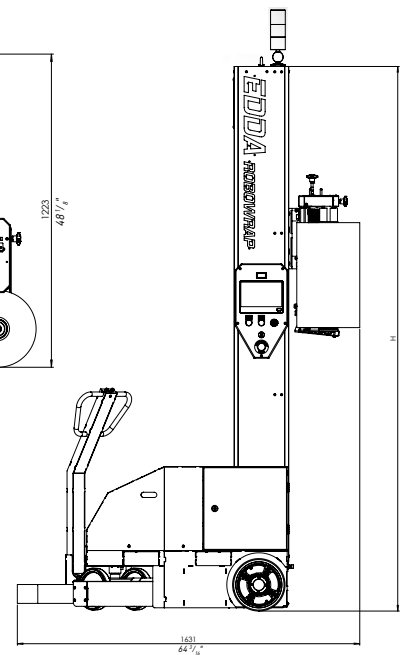
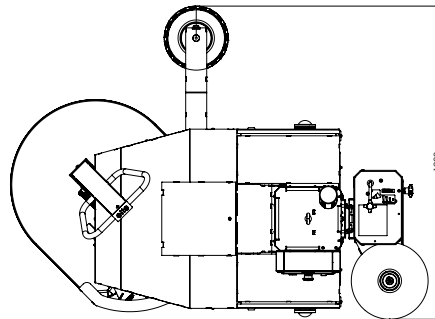

VERTICAL STRETCH FILM SERIES

TECHNICAL FEATURES

MACHINE GENERAL FEATURES

Machine Dimensions (L x W x H)	mm
Control & Drive Voltage Charger	V DC
*Charger Electric Supply	Volt - Hz
Film Tensioning System	
Film Tensioning Rate	[%]
Speed Adjustment	

ROBOWRAP 2700 MB

Machine Dimensions (L x W x H)	1630 x 1230 x 2700	64 ¹¹ / ₆₄ " x 48 ²⁷ / ₆₄ " x 106 ¹⁹ / ₆₄ "
Control & Drive Voltage Charger	24	
*Charger Electric Supply	220 Volt - 50/60 Hz Monophase	
Film Tensioning System	Mechanical Brake	
Film Tensioning Rate	0 - 100	
Speed Adjustment	Available	

ROBOWRAP 2700 VPT

Machine Dimensions (L x W x H)	1630 x 1230 x 2700	64 ¹¹ / ₆₄ " x 48 ²⁷ / ₆₄ " x 106 ¹⁹ / ₆₄ "
Control & Drive Voltage Charger	24	
*Charger Electric Supply	220 Volt - 50/60 Hz Monophase	
Film Tensioning System	Motorized Pre-Stretching	
Film Tensioning Rate	0 - 250	
Speed Adjustment	Available	

* 110 Volt 50/60 Hz Monophase (optional)

FILM ROLL FEATURES

Film Width	mm/inch	200 - 500	7 ⁷ / ₈ " - 19 ¹¹ / ₁₆ "	500	19 ¹¹ / ₁₆ "
Max. Roll Diameter	mm/inch	Ø250	9 ²⁷ / ₃₂ "	Ø250	9 ²⁷ / ₃₂ "
Max. Roll Weight	kg	16		16	
Roll Inner Diameter	mm/inch	Ø76	2 ⁶³ / ₆₄ "	Ø76	2 ⁶³ / ₆₄ "

PACKAGING DIMENSIONS

Max. Height	mm/inch	2700	106 ¹⁹ / ₆₄ "	2700	106 ¹⁹ / ₆₄ "
Max. Dimensions (W x D)	mm/inch	∞		∞	
Min. Dimensions (W x D)	mm/inch	700 x 700	27 ⁹ / ₁₆ " x 27 ⁹ / ₁₆ "	700 x 700	27 ⁹ / ₁₆ " x 27 ⁹ / ₁₆ "

