



UNPACK THE INNOVATIVE TECHNOLOGIES

SPEEDWRAP 550

 **EDDA**[®]
PACKAGING MACHINES

www.eddapack.com



This packaging solution is intended in particular for wrapping long and thin products by stretch film. The machine provides the perfect flat surface, speeds up the packaging process, saves packaging material in automatic mode with low noise level.

Packing speed is adjustable on the control panel. Control over the cycles is carried out by the software system that shown on the display.

The friction roller spool holder ensures constant film tension regardless of the outside diameter of the spool. This equipment is easy to learn to operate and requires very low maintenance.

The wrapping process is fully automatic and does not require the presence of an operator. The machines can be used as separate modules or integrated into existing production lines.



TECHNICAL FEATURES



PRODUCT TO WRAP SIZES

Max. Length		Unlimited	
Max. Width x Max. Height	mm/inch	260 x 270	10 ¹⁵ / ₆₄ " x 10 ⁵ / ₈ "
Min. Dimensions	mm/inch	70 x 18 x 1000*	2 ³ / ₄ " x 4 ⁵ / ₆₄ " x 39 ³ / ₈ "

CONVEYOR BELT'S FEATURES

Useful Length	mm/inch	950	37 ¹³ / ₃₂ "
Total Length	mm/inch	1050	41 ¹¹ / ₃₂ "
Working Height	mm/inch	920	36 ⁷ / ₃₂ "
Electric Motor Power	kW	0,55	
Max. Conveyor Speed	meter/min.	36	
Max. Load Capacity	kgs/meter	100	

STRETCH FILM FEATURES

Max. Width	mm/inch	170	6 ¹¹ / ₁₆ "
Max. Diameter	mm/inch	Ø 230	9 ¹ / ₁₆ " (Max. Weight: 3 kg.)
Reel Core Diameter	mm/inch	Ø 76	2 ⁶³ / ₆₄ "
Recommended Thickness	micron	23, 30, 35	

MACHINE GENERAL FEATURES

Main Motor Power	kW	1,1	
Max. Ring Rotation Speed	rpm	140	
Min. Ring Rotation Speed	rpm	30	
Standard Machine Dimensions (W x H x L)	mm/inch	1600 x 1664 x 2744	62 ⁶³ / ₆₄ " x 65 ³³ / ₆₄ " x 108 ¹ / ₃₂ "
Total Weight	kg	940	
*Electric Supply	Volt - Hz	380 Volt - 50/60 Hz - 3P + 1N + 1G	
Total Power	kW	2,3	

* 208 Volt, 380 Volt, 415 Volt, 480 Volt 50/60 Hz (optional)

The machine is equipped with improved component that allow the machine to work accurately, without failure and for a long time.



Monoblock Main Body with Protective Cover



Automatic Centering Side Press

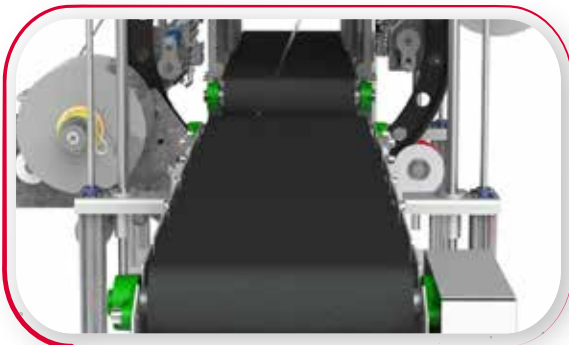

Motorized Conveyor

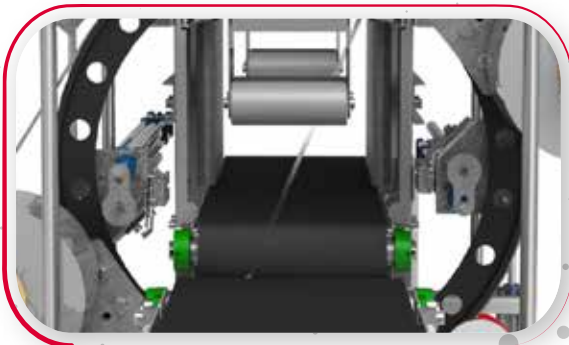

Double Stretch Film Cutting Unit

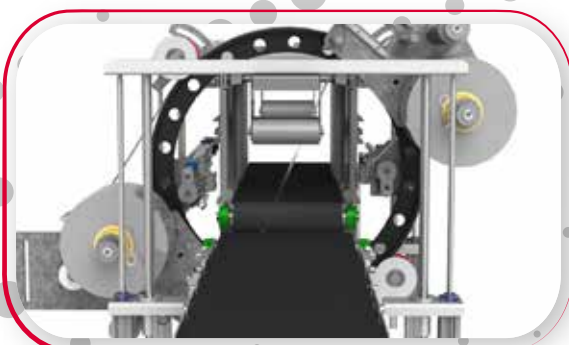

Double Stretch Film Carriage Unit

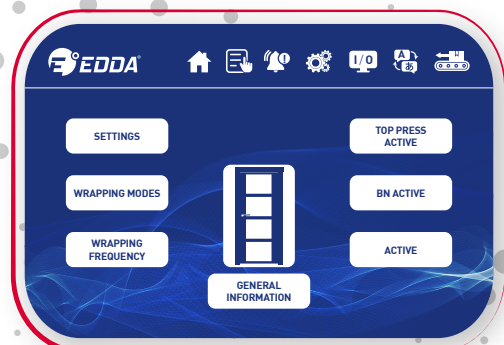

HMI Touch Panel

Some useful optional equipment. You can search for more with us.



Different Length
Motorized Conveyor



Non - Motorized
Reel Conveyor



C Wrap



Transfer Belt



Buffering Table

DO YOU
need any
optional
equipment

Keep your products in safe!

Flexible and universal packaging solutions for many industries. From small productions to huge manufacturing areas. Our team will help you to search the optimal equipment for your production needs.



Profile



Wood



Pipes



Metal

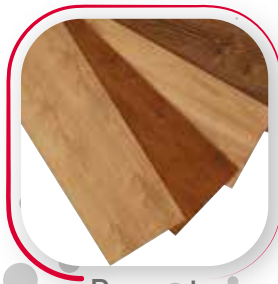

Parquet



Pvc Profile



Door jamb



WHICH
sector
is yours

Advantage contents applicable to carton box machine.



Productivity;

Provides reduction in energy consumption and cost of packaging materials.



Practicality;

User-friendly touch panel has 5 different operating modes and recipes.



Ergonomics;

It provides easy adjustment of the machine parameters by touch panel screen.



Protection;

Optimal protection of products from external factors, reducing damages during transportation.



Immutability;

It provides an uniform shape of the packaging standard for all products.



Flexibility;

It allows to pack workpieces with different heights, lengths and thickness.



Strength;

It contains the long-lasting parts for serial usage and operation.

WHAT
are the
main
advantages

All around the world

We have strong references and partners in many countries who provide all technical service, installation, training and spare part support. Our main principle is provide the immediate support.

We are servicing at

5
CONTINENTS

WHERE

we
are



 Büyükbalıklı Mah. 1. Ayça Sokak
No: 6, 16110, Nilüfer / BURSA

 +90 (850) 308 67 41

 info@eddapack.com

www.eddapack.com 



0323