

UNPACK THE INNOVATIVE TECHNOLOGIES

FRAMEWRAP 2200 S

 **EDDA**[®]
PACKAGING MACHINES

www.eddapack.com



The modern and optimal solution for window packaging. The window manufacturers often have difficulties and issues with packaging process, especially in large sizes. Lifting up, turning and moving the window makes job very hard, slow and dangerous.

FRAMEWRAP is that solution which make the process easy, fast and safe. This equipment is designed specifically for those production areas where the window production process is run in an inclined way.

The machine could be integrated to the production lines where the window will be fed to the wrapping station without changing the position of the window. The machine has motorized feeding system with automatic press unit which can fix sized dimensions of window

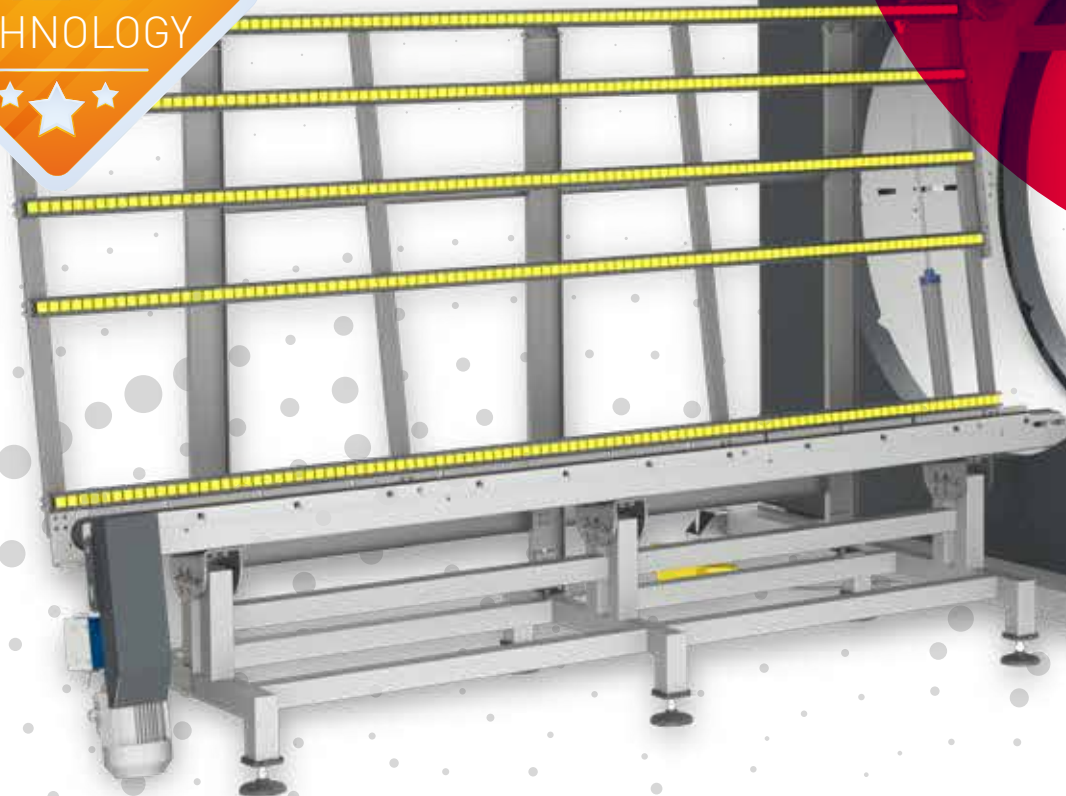

TECHNICAL FEATURES



FEEDING SYSTEM'S FEATURES

Useful Length	mm/inch	2950	116 ⁹ / ₆₄ "
Total Length	mm/inch	2953	116 ¹⁷ / ₆₄ "
Working Height	mm/inch	620	24 ¹³ / ₃₂ "
Electric Motor Power	kW	0,55	
Max. Conveyor Speed	meter/min.	12	
Max. Load Capacity	kgs/meter	100	

PRODUCT TO WRAP SIZES

Max. Length	Unlimited		
Max. Dimensions (Thickness x Height)	150 x 2050	5 ²⁹ / ₃₂ " x 66 ⁵⁹ / ₆₄ "	
Min. Dimensions (Thickness x Height x Length) mm/inch	40 x 900	1 ³⁷ / ₆₄ " x 37 ¹ / ₁₆ "	
	1200	* With Short Panel Nail 47 ¹ / ₄ "	

STRETCH FILM FEATURES

Max. Width	mm/inch	500	19 ¹¹ / ₁₆ "
Max. Diameter	mm/inch	Ø 250	9 ²⁷ / ₃₂ " (Max. Weight: 15 kg.)
Reel Core Diameter	mm/inch	Ø 76	3"
Recommended Thickness	micron	23, 30, 35	

MACHINE GENERAL FEATURES

Main Motor Power	kW	4,4
Max. Ring Rotation Speed	rpm	35
Min. Ring Rotation Speed	rpm	10
Standard Machine Dimensions (W x H x L)	mm/inch	3450 x 3150 x 6750
		135 ⁵⁹ / ₆₄ " x 124 ¹ / ₁₆ " x 265 ³ / ₄ "
Total Weight	kg	2050

The automation of the packaging process will allow you to streamline and give ideal view of the packaging.

The machine applies a continuous film wrap around the product. Thanks to the mechanical stretching system, the film is stretched up to 300%, which can significantly reduce the consumption of packaging materials.



Window

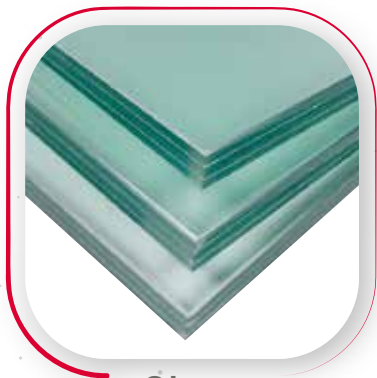

Glass



Door

WHICH
sector
is yours

Advantage contents applicable to carton box machine.



Productivity;

Provides reduction in energy consumption and cost of packaging materials.



Practicality;

User-friendly touch panel has 5 different operating modes and recipes



Ergonomics;

It provides easy adjustment of the machine parameters by touch panel screen



Protection;

Optimal protection of products from external factors, reducing damages during transportation.



Immutability;

It provides an uniform shape of the packaging standard for all products.



Flexibility;

It allows to pack workpieces with different heights, lengths and thickness.



Strength;

It contains the long-lasting parts for serial usage and operation.

WHAT
are the
main
advantages

All around the world

We have strong references and partners in many countries who provide all technical service, installation, training and spare part support. Our main principle to provide the immediate support.

We are servicing at

5
CONTINENTS

around the World

WHERE

we
are



 Büyükbalıklı Mah. 1. Ayça Sokak
No: 6, 16250, Nilüfer / BURSA

 +90 (850) 308 67 41

 info@eddapack.com

www.eddapack.com 

